

Data Structures in Coco/R

Hanspeter Mössenböck
Johannes Kepler University Linz
Institute of System Software
April 2005

This technical note describes the data structures in the C# and Java implementations of the compiler generator Coco/R. The major data structures are:

- **The Symbol table** (Classes: `Symbol`). All terminals, pragmas and nonterminals in linear sequence. This data structure is trivial and therefore not further described.
- **The Syntax graph** (Classes: `Node`, `Graph`). The productions of the grammar as separate subgraphs. For every nonterminal sym there is a pointer `sym.graph` to the root of this symbol's syntax graph. A snapshot of this data structure is described in Section 1.
- **The Scanner automaton** (Classes: `State`, `Action`, `Target`, `Melted`). The DFA generated from token declarations. The token declarations are first translated to a syntax graph which is then transformed into a deterministic finite automaton. These steps are shown in Section 2.
- **The Character classes** (Class: `CharClass`). The character sets declared in the grammar stored as a linear list. This data structure is trivial and therefore not further explained.
- **The literals table** (Class: `Tab`). A mapping between token names and their literal representation.

1. Syntax Graph

Production: $A = (a \{b\} c \mid d [e] f \mid) g.$

Graph:

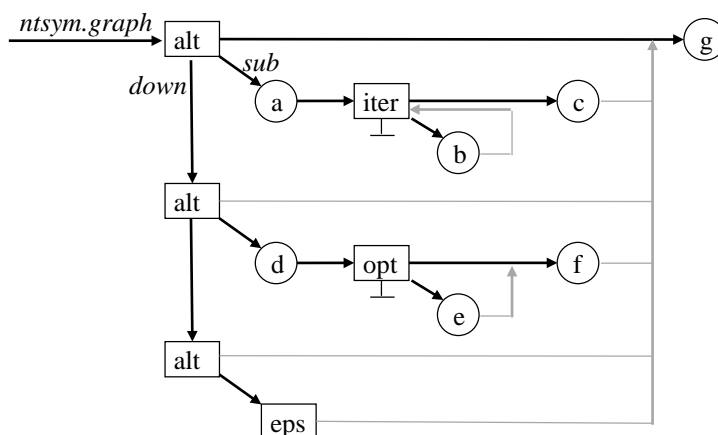

Gray lines denote `next` pointers that point upwards. For any node `n`, if `n.next` points upwards, then `n.up` is true.

Operations to build the syntax graph

Tab.MakeFirstAlt(g)

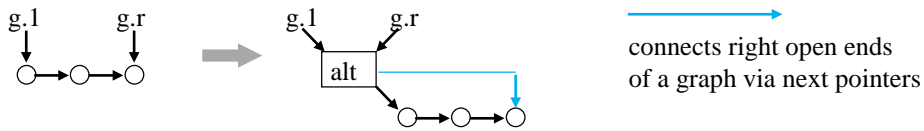

Tab.MakeAlternative(g1, g2)

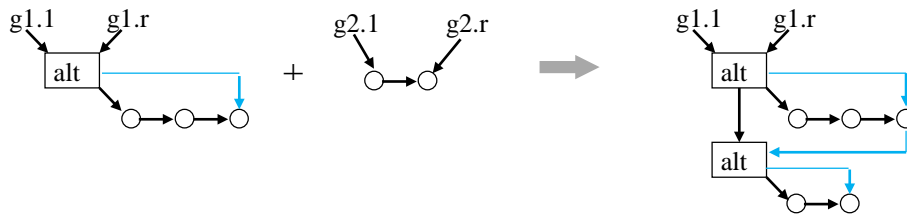

Tab.MakeSequence(g1, g2)

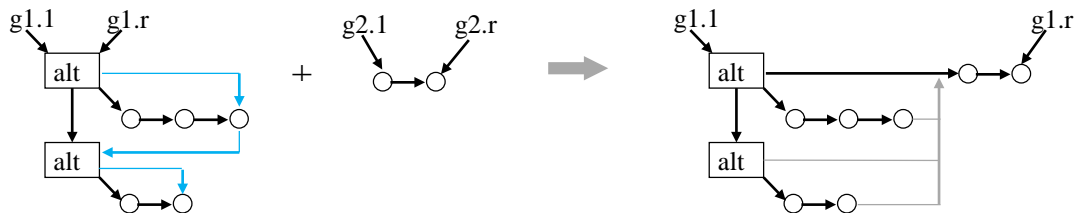

Tab.MakeOption(g)

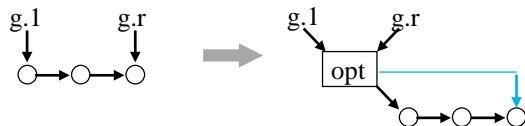

Tab.MakeIteration(g)

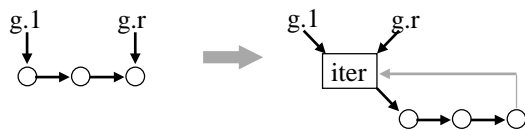

Tab.Finish(g)

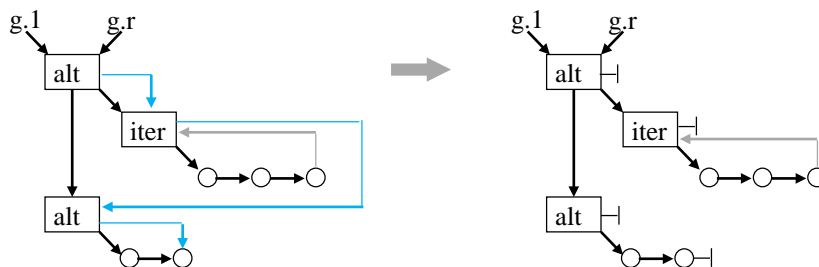

2. Scanner automaton

Declarations

```
CHARACTERS
  digit = '0'..'9'.
  hex   = digit + 'a'..'f'.
TOKENS
  number = digit {digit}.
  hexnum = digit {digit} 'H'.
  special = "0x".
```

Syntax graph for the tokens

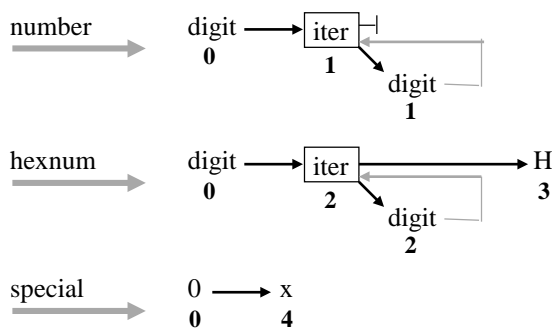

The bold numbers denote the states that were assigned to the nodes by the method `DFA.NumberNodes`. They are used to derive the automaton from the graph as follows: if a node for a character or a character class `c` has the number `n` and its `next` pointer points to a node with a number `m`, then this leads to a transition

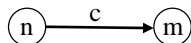

If there is no `next` node, the transition leads to a new state.

Nondeterministic automaton

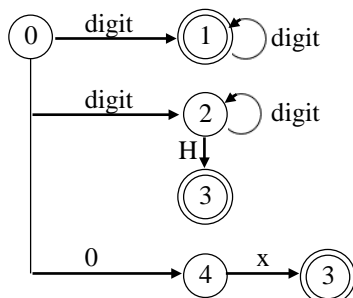

The automaton is nondeterministic since there are two transitions with `digit` in state 0 and (since `'0'` is also a `digit`) there are three transitions with `'0'` in state 0. The first step in making the automaton deterministic is to split overlapping character ranges. This is done by `DFA.MakeUnique`.

After MakeUnique

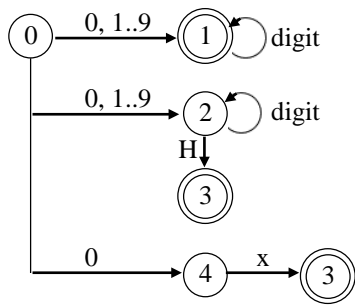

The next step is to melt those states that can be reached by a transition with the same symbol from the same state. This is done in `DFA.MeltStates`.

After MeltStates

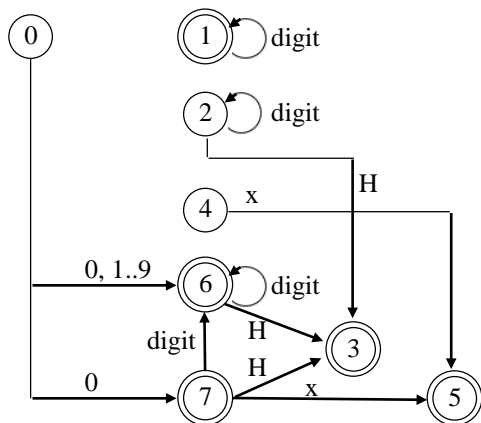

The only remaining task now is to delete the redundant states (here 1, 2 and 4).

After DeleteRedundantStates

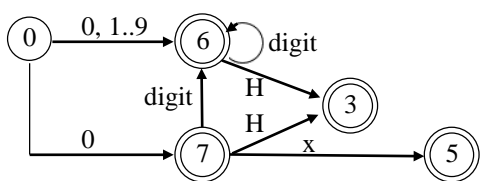

This is the resulting deterministic finite automaton from which the scanner is generated.

Concrete data structures

Nondeterministic automaton

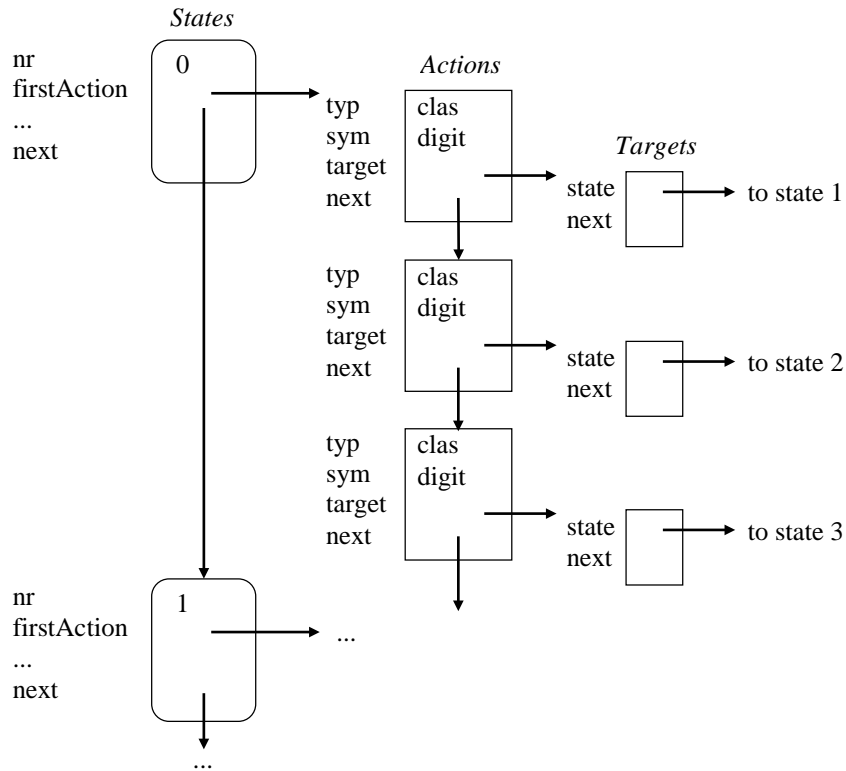

After MakeUnique

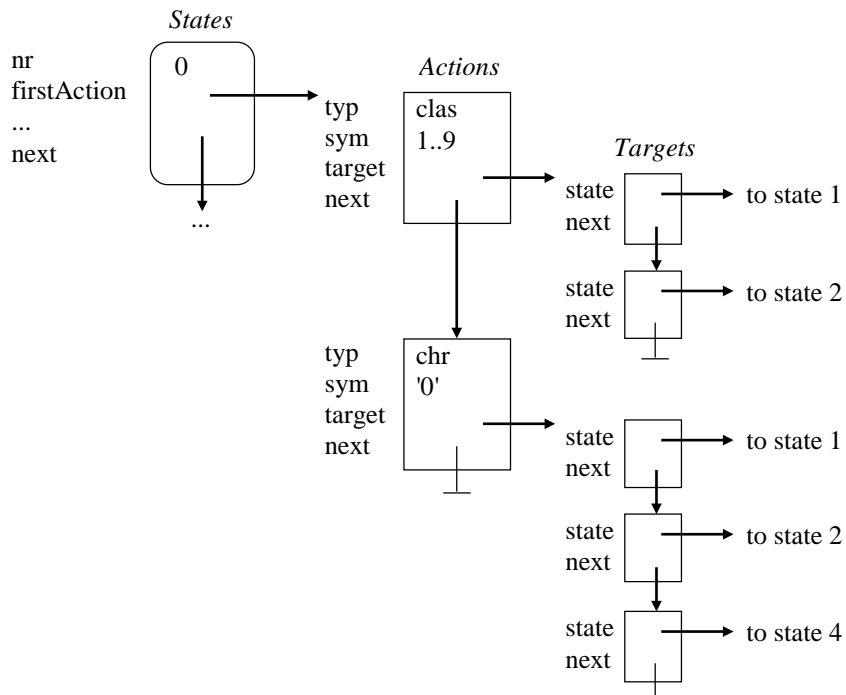

This means: from state 0 one can go with the characters 1..9 to state 1 and 2, and with the character 0 to state 1, 2 and 4.

After MeltStates

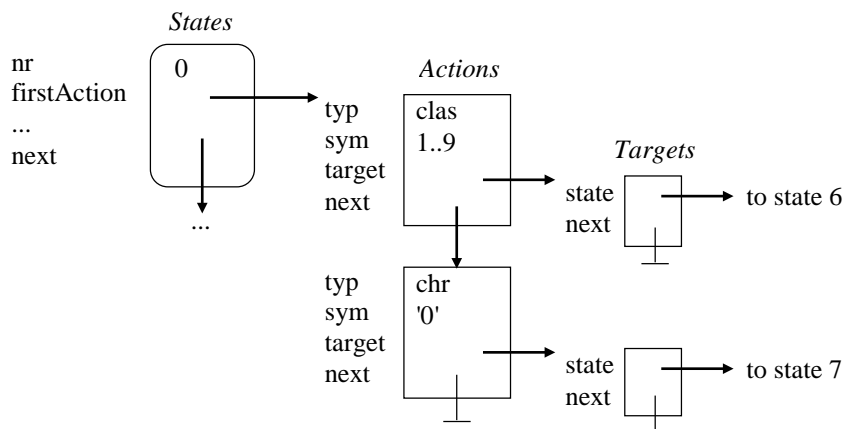

The states 1 and 2 have been "melted" into a new state 6, the states 1, 2 and 4 have been melted into a new state 7. This information is kept in class `Melted` using the following data structure:

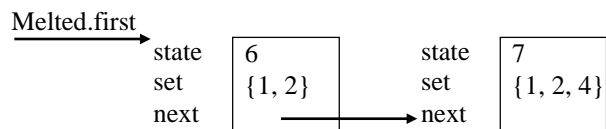

The literals table

If a token is explicitly declared as a string, e.g.:

```
TOKENS
  while = "while".
  ...
```

it can be referenced in the productions both by its name (`while`) and by its literal representation (`"while"`). The symbol table just stores the names of such tokens. The hash table `Tab.literals` is used to map their literal representation to their node in the symbol table.